

# 17544

17545, 17546, 17547, 17610, 17611

## FLAT TILE ROOF HOOK FOR BOTTOM MOUNT RAILS



A DIVISION OF QUICKSCREWS INTERNATIONAL CORP

# TABLE OF CONTENTS

3

## SPEC SHEET

QTY & MEASUREMENT INFORMATION

---

4

## UL CERTIFICATION

PROOF OF UL CERTIFICATION

---

6

## INSTALLATION INSTRUCTIONS

STEP-BY-STEP-INSTALLATION GUIDE

---

7

## BUILDING CODE LETTER

REGARDING STAMP DATES

---

8

## ENGINEERING REPORT

UPLIFT & LATERAL LOAD TEST

---

# SPEC SHEET

Part #	Box Quantity	Screw Size
17544	20 Hooks	N/A
17545	1 Hook	N/A
17546	20 Hooks; 40 Screws	#14 x 3"
17547	1 Hook; 2 Screws	#14 x 3"
17610	20 Hooks; 40 Screws	5/16" x 3"
117611	1 Hook; 2 Screws	5/16" x 3"



Letter	Description	Size/Length
A	Mounting Screw Holes	9mm
B	Rail Attachment Slot	10mm x 38mm
C	Length of Roof Hook	285mm
D	Bottom End to Top End	138mm
E	Thickness	5mm

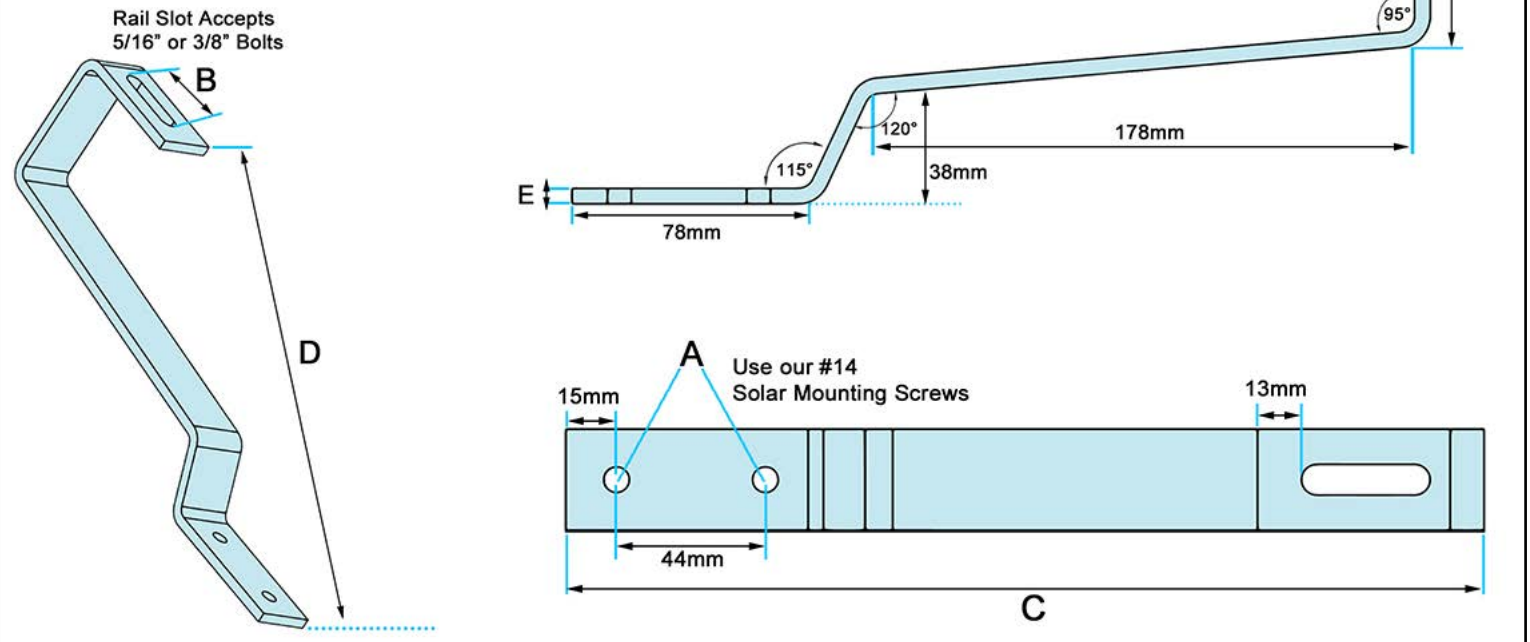

## CERTIFICATE OF COMPLIANCE

**Certificate Number** E493748  
**Report Reference** E493748-20170817  
**Date** 2023-April-07

**Issued to:** QuickBOLT a Division of Quickscrews International Corp  
5830 Las Positas Rd  
Livermore CA, 94551 US

**This is to certify that representative samples of** MOUNTING SYSTEMS, MOUNTING DEVICES, CLAMPING DEVICES AND GROUND LUGS FOR USE WITH PHOTOVOLTAIC MODULES AND PANELS - COMPONENT  
See Addendum Page for Product Designation(s).

Have been evaluated by UL in accordance with the component requirements in the Standard(s) indicated on this Certificate. UL Recognized components are incomplete in certain constructional features or restricted in performance capabilities and are intended for installation in complete equipment submitted for investigation to UL LLC.

**Standard(s) for Safety:** UL 2703, Mounting systems, mounting devices, clamping/retention devices, and ground lugs for use with flat-plate photovoltaic modules and panels-.

**Additional Information:** See the UL Online Certifications Directory at <https://iq.ulprospector.com> for additional information

This Certificate of Compliance indicates that representative samples of the product described in the certification report have met the requirements for UL certification. It does not provide authorization to apply the UL Recognized Component Mark. Only the Authorization Page that references the Follow-Up Services Procedure for ongoing surveillance provides authorization to apply the UL Mark.

Only those products bearing the UL Recognized Component Mark should be considered as being UL Certified and covered under UL's Follow-Up Services.

Look for the UL Recognized Component Mark on the product.

*Deborah Jennings-Conner*

Deborah Jennings-Conner, VP Regulatory Services

UL LLC

Any information and documentation involving UL Mark services are provided on behalf of UL LLC (UL) or any authorized licensee of UL. For questions, please contact a local UL Customer Service Representative at <http://ul.com/aboutul/locations/>



# CERTIFICATE OF COMPLIANCE

**Certificate Number** E493748  
**Report Reference** E493748-20170817  
**Date** 2023-April-07

This is to certify that representative samples of the product as specified on this certificate were tested according to the current UL requirements

**Models:**

USR – Component, Roof Mounting Hook Units, Models 15891 15893 15987 16000 16317 16318  
16319 16320 16988 16990 16991 16993 17508 17509 17510 17511 17512 17513 17514 17515  
17516 17517 17518 17519 17520 17521 17522 17523 17524 17525 17526 17527 17536 17537  
17538 17539 17540 17541 17542 17543 17544 17545 17546 17547 17548 17549 17550 17551  
17552 17553 17554 17555 17556 17558 17559 17560 17566 17567 17568 17569 17570 17571  
17572 17573 17574 17575 17576 17577 17578 17579 17580 17585 17586 17587 17588 17589  
17592 17596 17597 17598 17599 17600 17601 17606 17607 17608 17609 17610 17611 17612  
17613 17614 17615 17616 17617 17618 17620 17621 17622 17623 17624 17625 17626 17627  
17628 17629 17630 17631 17632 17633 17636 17637 17638 17639 17640 17641 17642 17643  
17646 17647 17648 17649 17650 17651 17652 17653 17654 17659 17664 17667 17669 17670  
17671 17672 17673 17678 17679 17680 17681 17686 17687 17688 17689 17700 17701 17702  
17703 17704 17705 17706 17707 17708 17709 17710 17711 17712 17717 17718 17750 17751  
17752 17753 17759 15891-10 15891BLK-10 15987A 15987B 17667SS 17672SS 17680SS  
17688SS 17713SS 17720 17721SS 17723 17724SS 17726 17727SS 17729 17730SS 15894SS  
15891SS 15987BSS 17660 17661 17662 17663 17747 17748

*Deborah Jennings-Conner*

Deborah Jennings-Conner, VP Regulatory Services

UL LLC

Any information and documentation involving UL Mark services are provided on behalf of UL LLC (UL) or any authorized licensee of UL. For questions, please contact a local UL Customer Service Representative at <http://ul.com/aboutul/locations>



# INSTALL INSTRUCTIONS



## RECOMMENDED MATERIALS

- Rafter locator
- Chalk or crayon
- Drill Bit
- Manufacturer's approved sealant

## INSTALLATION INSTRUCTIONS

1. Remove the tiles from the install area
2. Locate and mark the rafters
3. Place the mount and predrill holes
4. Fill the predrilled holes with mfg. approved sealant
5. Drive the Mounting Screws
6. Place the tiles back over the roof mount

## IF USING GALVA FLASHING

1. Make a cut in the paper
2. Apply sealant to the underside of the Galva Flashing
3. Slide the Flashing underneath the paper or nail down edges
4. Cover the edges of the Galva Flashing with sealant



# BUILDING CODE LETTER



March 22<sup>nd</sup>, 2023

To whom this may concern,

QuickBOLT is committed to excellence. The parts tested are durable goods, meaning the material composition and detailed specifications of the parts do not change. Therefore, all stamps are current. Any part tested will have the same results no matter what year the tests are performed. All testing and reports are current and valid with 2022 CBC standards.

SolarRoofHook is the previous name of QuickBOLT. Any test result referencing SolarRoofHook is referring to a QuickBOLT product.

All our parts were tested by a third-party test facility, in possession of a current engineering license for the state where the tests were performed for the following.

1. Uplift test
2. Downward load test
3. Lateral Test – Asphalt Mounts, and Metal Mounts only
4. ASTM E2440 and ASTM E330 Waterproof Tests - QuickBOLT only

The following is an excerpt from:

CALIFORNIA BOARD FOR PROFESSIONAL ENGINEERS AND LAND SURVEYORS  
guide to Engineering & Land Surveying for City and County Officials  
Page 12, Line 27

**27. If the license has expired between the time the engineering documents were prepared and the time when the local agency's review is performed, do the documents need to be re-sealed by a licensee with a current license? (B&P Code §§ 6733, 6735, 6735.3, 6735.4)**

**As long as the license was current at the time the engineering documents were prepared, the documents do not need to be re-sealed prior to review by the local agency. However, any changes (updates or modifications) to the documents that are made following the review by the local agency would have to be prepared by a licensed engineer with a current license and those changes would have to be signed and sealed.**

We trust the information provided will resolve any request for the test reports submitted to have a stamp from the current year.

Regards,

Rick Gentry  
Executive Vice President

# ENGINEERING REPORT



APPLIED MATERIALS & ENGINEERING, INC.

980 41<sup>st</sup> Street  
Oakland, CA 94608

Tel: (510) 420-8190  
FAX: (510) 420-8186  
e-mail: [info@appmateng.com](mailto:info@appmateng.com)

January 25, 2011

Mr. Rick Gentry  
**QUICKSCREWS INTERNATIONAL**  
5830 Las Positas Road  
Livermore, CA 94551

Project Number 111003C

**Subject:** PV Bracket Laboratory Load Testing

Dear Mr. Gentry:

As requested, Applied Materials & Engineering, Inc. (AME) has completed load-testing PV bracket hardware. The purpose of our testing was to evaluate the tensile and compressive load capacity of the PV bracket attached to a 2"x4" Douglas Fir rafter using #12 Quickscrew and 1/4" lag bolt.

## **SAMPLE DESCRIPTION**

Six (6) mockup samples were delivered to our laboratory on December 28, 2010. Mockup configuration consisted of three 16" long rafters at 7" o.c., screwed to 1/2" OSB sheathing. The PV bracket is attached through the OSB into the rafter with two fasteners.

## **TEST PROCEDURES & RESULTS**

### **1. Compressive Load Test**

A total of six tests were conducted for compressive load capacity on January 10, 2011 using a United Universal testing machine. Three tests were performed using #12 Quickscrew (0.216"Øx 3" L) and three tests were performed using 1/4" x 2.5" long lag bolt. Samples were rigidly attached to the testing machine and a compressive load was applied to the 1/4"x1" machine bolt connected to the L-Feet. The samples were loaded in compression at a constant rate of axial deformation of 0.09 in./min. without shock until the bracket was in contact with the OSB sheathing; maximum deflection at maximum load was recorded. Detailed results are provided in Table I. Test setup and typical bracket bending at maximum load are provided in Appendix A. Based on the above testing, the average maximum compression load of the PV bracket attached to a 2"x4" Douglas Fir rafter using #12 Quickscrew and 1/4" lag bolt Fir rafter were determined to be 114 lbf and 119 lbf, respectively.

### **2. Tensile Load Test**

A total of six tests were conducted for tensile load capacity on January 19, 2011 using a United Universal testing machine. Three tests were performed using #12 Quickscrew (0.216"Øx 3" L) and three tests were performed using 1/4" x 2.5" long lag bolt. Samples were rigidly attached to the testing machine and a tensile load was applied to the 1/4"x1" machine bolt connected to the L-Feet.



Mr. Rick Gentry  
QUICKSCREWS INTERNATIONAL  
PV Bracket Load Testing  
January 25, 2011

Project Number 111003C

The samples were loaded in tension at a constant rate of axial deformation of 0.09 in. /min. without shock until the bracket was bent and the bolt began to pull-out; maximum deflection at maximum load was recorded. Detailed results are provided in Table II. Test setup and typical bracket bending at maximum load are provided in Appendix A. Based on the above testing, the average maximum tensile load of the PV bracket attached to a 2"x4" Douglas Fir rafter using #12 Quickscrew and 1/4" lag bolt Fir rafter were determined to be 253 lbf and 255 lbf, respectively.

### 3. Specific Gravity of Wood

The specific gravity and moisture content of the lumber (rafter) were tested in accordance with ASTM D2395, Method A (oven-dry) and was determined to be 0.356 and 10.8 %, respectively.

If you have any questions regarding the above, please do not hesitate to call the undersigned.

Respectfully Submitted,

**APPLIED MATERIALS & ENGINEERING, INC.**

**Reviewed By:**

  
Mohammed Faiyaz  
Laboratory Manager

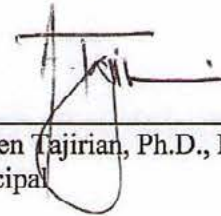

  
Armen Tajirian, Ph.D., P.E.  
Principal

**TABLE I**  
**COMPRESSIVE LOAD TEST RESULTS**  
**PV BRACKET**  
**PROJECT NUMBER 111003C**

<b>SAMPLE ID</b>	<b>ANCHOR / RAFTER</b>	<b>MAXIMUM COMPRESSIVE LOAD (lbf)</b>	<b>MAXIMUM DEFLECTION (in.)</b>
QS-C-1	#12 Quickscrew/ Douglas Fir	105	1.20
QS-C-2	#12 Quickscrew/ Douglas Fir	112	1.39
QS-C-3	#12 Quickscrew/ Douglas Fir	123	1.56
<b>AVERAGE</b>	...	<b>114</b>	<b>1.37</b>
LB-C-1	1/4" Lag Bolt / Douglas Fir	114	1.48
LB-C-2	1/4" Lag Bolt / Douglas Fir	116	1.46
LB-C-3	1/4" Lag Bolt / Douglas Fir	126	1.50
<b>AVERAGE</b>	...	<b>119</b>	<b>1.48</b>

Note: The failure mode for all of the above tests was bent bracket.

**TABLE II**  
**TENSILE (UPLIFT) LOAD TEST RESULTS**  
**PV BRACKET**  
**PROJECT NUMBER 111003C**

<b>SAMPLE ID</b>	<b>ANCHOR / RAFTER</b>	<b>MAXIMUM TENSILE LOAD (lbf)</b>	<b>MAXIMUM DEFLECTION (in.)</b>
QS-T-1	#12 Quickscrew/ Douglas Fir	255	3.7
QS-T-2	#12 Quickscrew/ Douglas Fir	252	3.5
QS-T-3	#12 Quickscrew/ Douglas Fir	252	3.1
<b>AVERAGE</b>	...	<b>253</b>	<b>3.5</b>
LB-T-1	1/4" Lag Bolt / Douglas Fir	256	3.4
LB-T-2	1/4" Lag Bolt / Douglas Fir	256	3.2
LB-T-3	1/4" Lag Bolt / Douglas Fir	252	3.2
<b>AVERAGE</b>	...	<b>255</b>	<b>3.2</b>

Note: The failure mode for all of the above tests was bent bracket.